

ATC[®] SCHNITZER

-Fitting Instructions-

Clip-on bars

BMW R nineT



Part No.: S217-67171-15

General Notes!



AC Schnitzer Clip-on bars BMW R nineT

Important Notes!

Important Notes!

These Fitting Instructions must be read carefully before starting work, and do not claim to be complete in relation to every work step. Technical, editorial and content changes are reserved!! AC Schnitzer bears no liability for damage caused by incorrect installation!

Check goods for completeness and absence of damage before starting work.
Later complaints cannot be accepted.

These Fitting Instructions are intended solely for use by authorised AC Schnitzer or BMW dealers. These Fitting Instructions are in all cases directed at professionals trained in BMW vehicles who have the corresponding specialist knowledge and tools. Knowledge concerning material properties, standards and tightening torques is assumed!

Before installation:

For installation, protect the vehicle adequately against rolling away or falling over.

We recommend the use of the normal main stand or an original BMW assembly stand. Keep children and animals away from the working area.

There is a risk of accident from tripping or electrical short-circuit. Therefore remove all jewellery (chains, watches, rings etc.) before starting work.

After installation:

After completion of the work, carry out a test ride. After the test ride, check all bolt connections for tightness and ensure that all moving parts have adequate clearance.

Fitting Time (1 unit = 5 minutes)

The fitting time is around **24 units**, which may vary depending on vehicle condition and equipment level.
(This value is a recommendation only and is not binding!)

Tools Required

- Standard automotive tools
- ⇒ plus: Hex socket SW 36
- Standard torx drivers
- ⇒ plus: Torx driver Tx 8
- Adhesive tape
- Torque wrench 2 - 100 Nm
- Motorbike scissor jack
- Medium-strength thread lock
- Drill / 4 mm bit
- Marker pen

AC Schnitzer Clip-on bars BMW R nineT

Chapter	Page
1. Components supplied	4
2. Fitting the AC Schnitzer clip-on bars	5

Components Supplied



AC Schnitzer Clip-on bars BMW R nineT

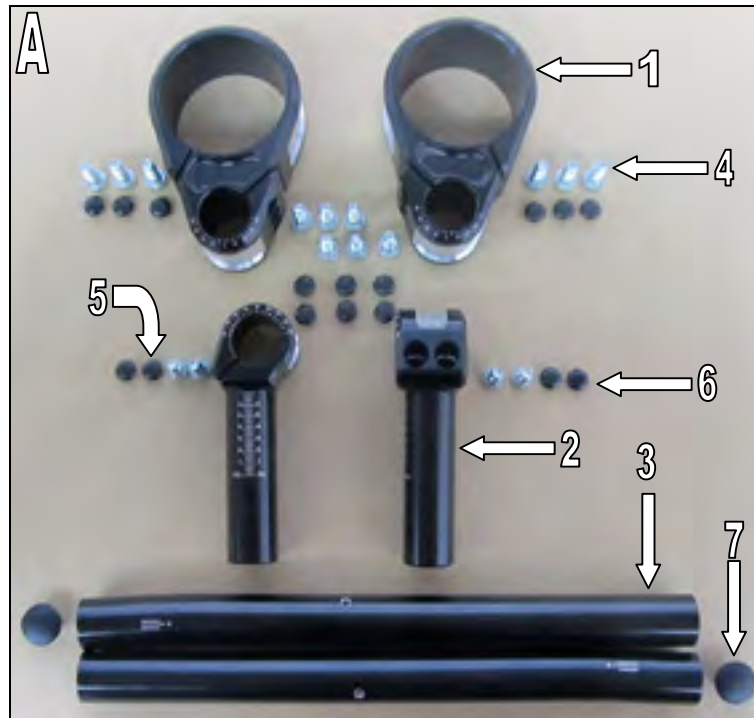

A:

- 1) 1x hose clamp for upright for each side left / right (**note L/R marking**)
- 2) 1x height adjustment for each side left / right
- 3) 1x handlebar stump for each side left / right
- 4) 12x M6x16 pan-head screw
- 5) 4x M6x12 pan-head screw
- 6) 16x caps for screw heads
- 7) 2x stump cover cap
- 8) 1x thread-lock (not shown)

B:

- 1x component certificate

Fitting Instructions No.: S217-67171-15 / Issue: 08 / 2014 RVo

AC Schnitzer - Neuenhofstraße 160 - D - 52078 Aachen - Tel. 0241/5688 -300 Fax -135 / www.ac-schnitzer.de

AC Schnitzer Clip-on bars BMW R nineT

2. Fitting

- Park vehicle securely and protect against falling or rolling away.
- Protect fuel tank from damage.
- Use scissor jack to raise front wheel.
- On both sides of the vehicle:
 - Remove the handlebar end weights.
 - Remove rear-view mirror (remove lower fixing screw).
 - Remove cables for grip heater/electrical units from rubber straps and fixings.
 - Remove brake line from fixing/bracket. (Fig. 1)

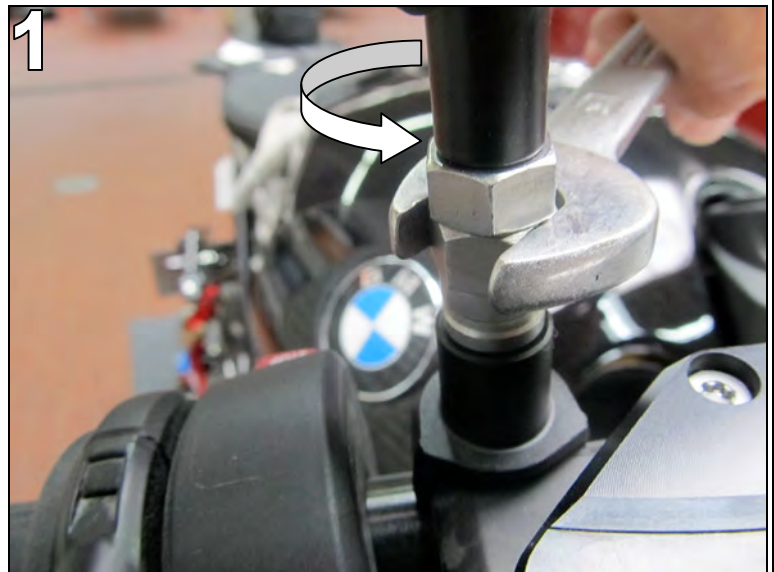

- On both handlebar sides, remove the hand fittings by unscrewing the bearing shells completely. Lay hand fittings down so that no air can enter the hydraulic system. (Fig. 2)

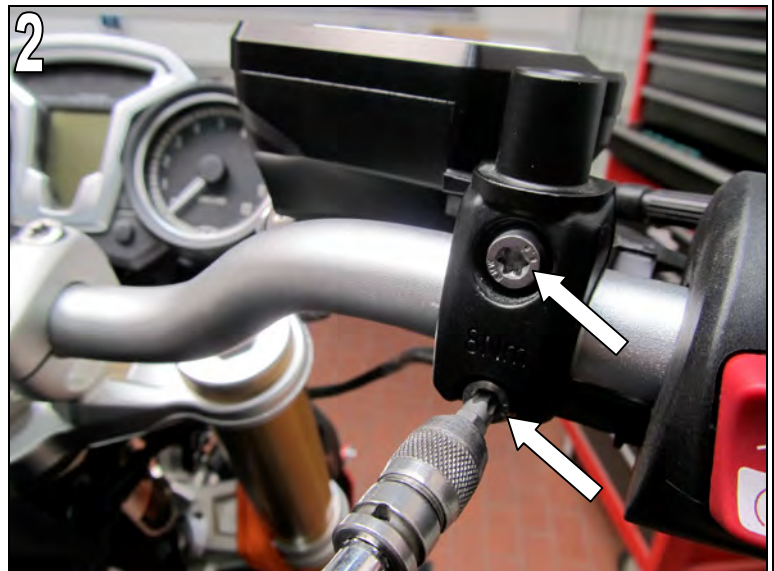

- On the left handlebar grip, fold back the rubber and unscrew the fixing screw underneath completely. Ensure that the fixing nut (opposite) is not lost.
- Do not try to pull the electrical unit off yet! (Fig. 3).



Fitting Instructions

AC Schnitzer Clip-on bars BMW R nineT

2. Fitting... (cont'd.)

- On the right grip, remove the lower cover by fully unscrewing the fixing screw using a Torx driver (Tx 8). Unscrew fixing screw completely. (Fig. 4)

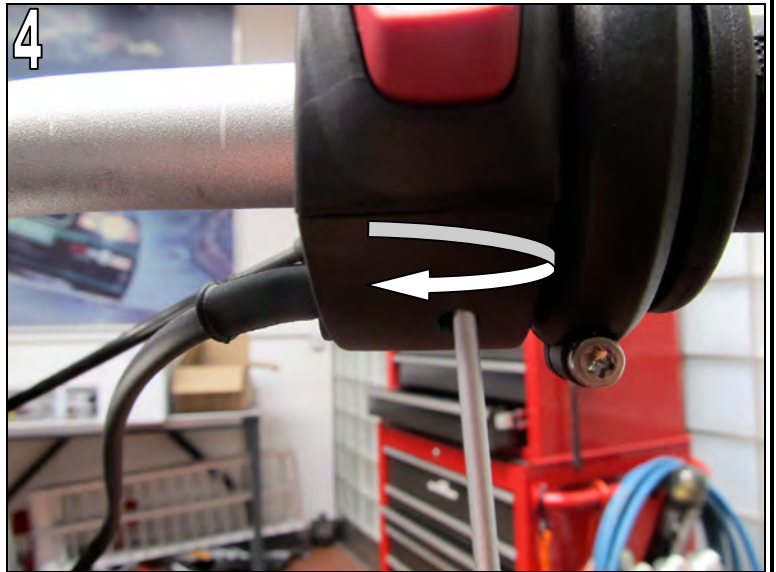

- On the exposed electrical unit, separate plug connections, undo the fixing screw and remove the electrical unit. (Fig. 5)

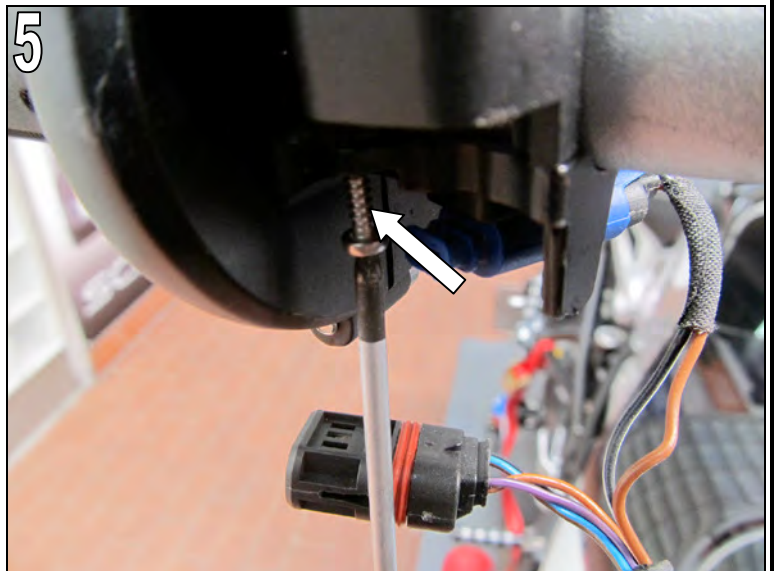

- Fully unscrew the fixing screw for the throttle twist grip. Do not try to pull the throttle twist grip off yet! (Fig. 6).



AC Schnitzer Clip-on bars BMW R nineT

2. Fitting... (cont'd.)

- Unscrew fully all 4 fixing screws on the handlebar clamp, and remove the upper clamping block. Ensure that the handlebars do not swing down and damage the fuel tank or similar. Remove the handlebars from the bearing shell, pull the throttle twist grip (right) and electrical unit (left) off the handlebar and lay these down. (Fig. 7)

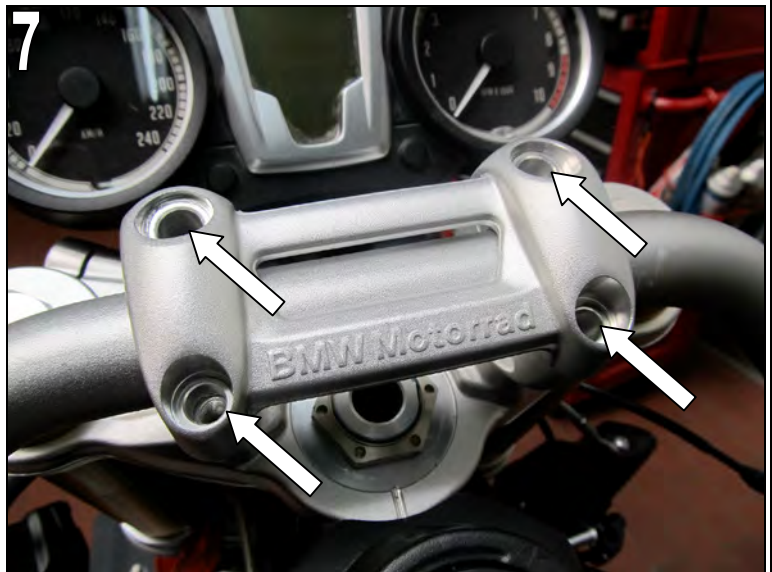

- Twist the lower bearing shells of the handlebar clamp one way and the other, and at the same time pull off upwards.
- To cover the exposed fixing holes, use cover kit: S700-68810-11 (not included with the Handlebar conversion). (Fig. 8)

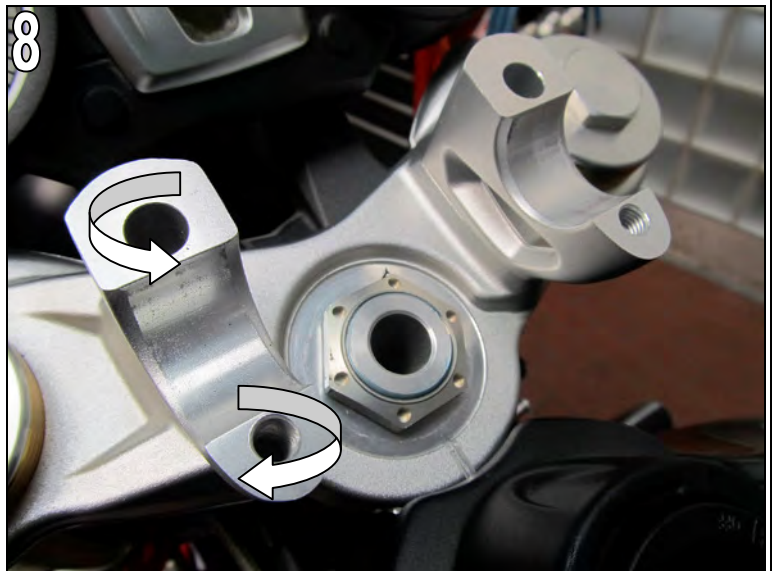

- Loosen the right & left fixing screws of the fork bridge clamp on the upright by approx. 2 turns. (Fig. 9).

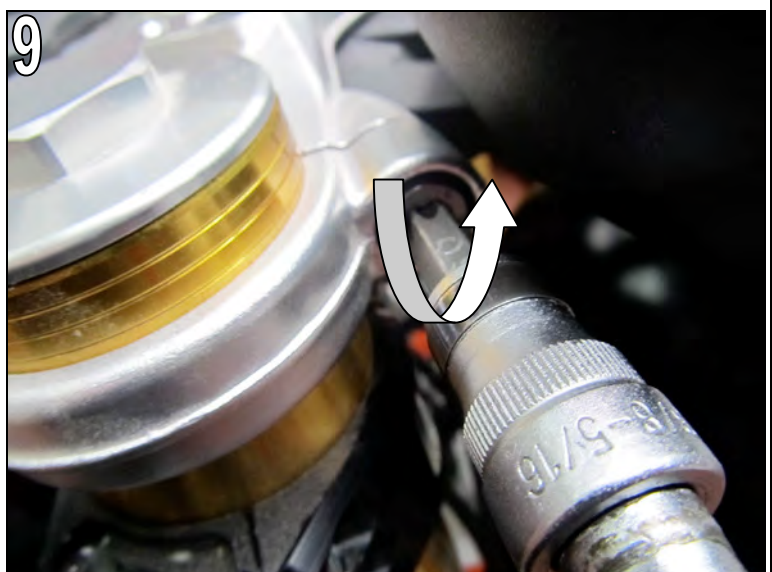

AC Schnitzer Clip-on bars BMW R nineT

2. Fitting... (cont'd.)

- Carefully pull off the cover of the ignition/steering lock upward.
- Release the central fixing nut of the fork bridge using the socket (SW 36) and remove this nut with washer. To do this, place fabric tape or similar on the socket first to prevent scratching the fork bridge. (Fig. 10)



- Raise front wheel on scissor jack and remove fork bridge and display unit upward from the upright.
- Clean thread. (Fig. 11)

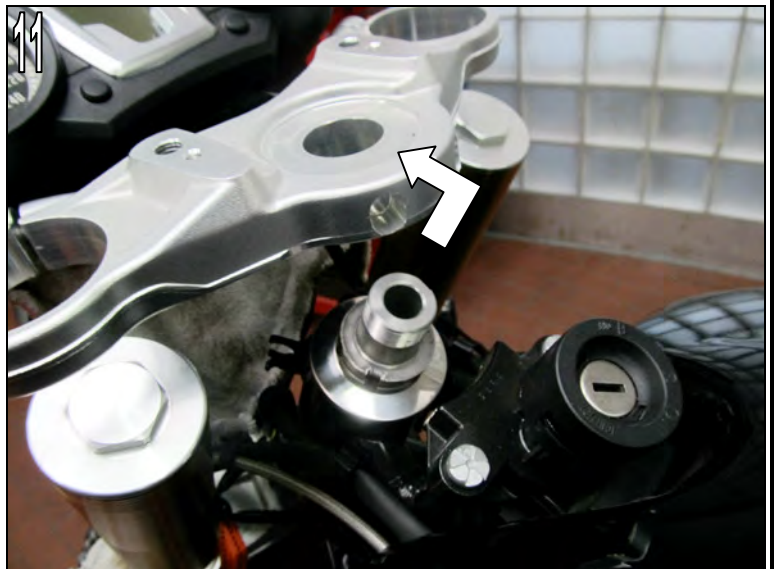

- On both sides:
 - Coat bolts (M6x 16) supplied lightly with the thread-lock provided and screw loosely into the base part.
 - Spread base part slightly with plastic wedge and push over the upright from above. Ensure that the approval number is at the BOTTOM. The "L" marking indicates the base part on the LEFT side viewed in the direction of travel. (Fig. 12).



Fitting Instructions

AC Schnitzer Clip-on bars BMW R nineT

2. Fitting... (cont'd.)

- Refit standard fork bridge down to the stop.
- Apply washer.
- Coat locking nut (M28 x 1) with medium-strength thread-lock and tighten.
Tightening torque: 100 Nm.
- Tighten fixing nuts on upright clamp (M8 x 25).
Tightening torque: 19 Nm.
- Lower front wheel again, push ignition lock cover back on. (Fig. 13)



- Align the positioned base parts:
 - ~ 90° to the vehicle longitudinal axis, then around 10° to the rear.
 - ~ 20 mm below the upper fork bridge
- Tighten fixing bolts for the base part clamp on the fork bridge. (Fig. 14)



- On both sides:
- Coat fixing bolts of stump holder (M6 x 12) with thread-lock supplied, and loosely screw into stump holder.
 - Insert stump holder into base part as shown. Ensure that the fixing bolts are pointing towards the driver and the markings line up.
 - Push in stump holder to position "2" and twist around 10° to the rear. Tighten clamping bolts on base part. (Fig. 15).



AC Schnitzer Clip-on bars BMW R nineT

2. Fitting... (cont'd)

On both sides:

- Press end plugs into handlebar stumps
- Fit throttle twist grip (right) and electrical unit (left) onto handlebar stumps. (Fig. 16)

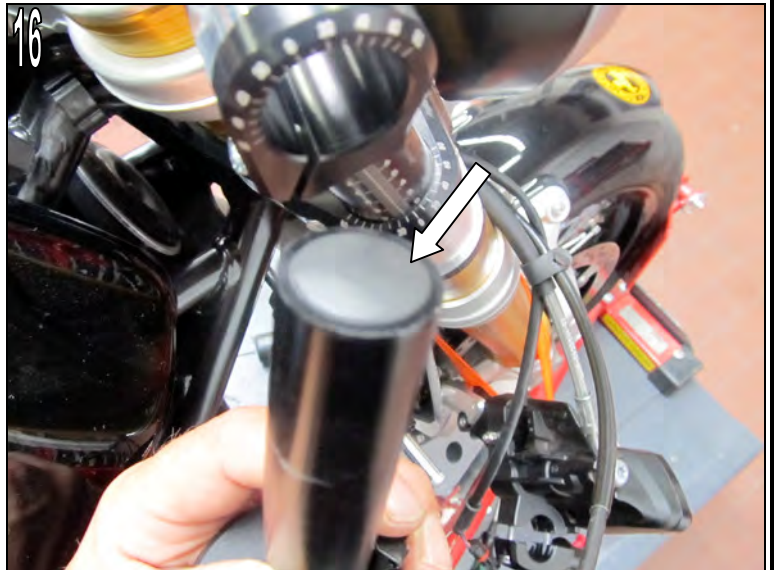

On both sides:

- Push handlebar stumps flush into stump holder. (Fig. 17)



On both sides:

- Align stump to base position 0° and tighten fixing screws.
- The stump has a 5° crank. Establish the final position of the unit or stump (optionally with the rider).
- Where applicable, mount hand fittings.
- Carefully turn handlebars to right and left and check clearance and position in relation to the tank, and adjust if necessary via the base part position and/or stump holder position.
- Do not adjust stump holder over the "max." position! (Fig. 18).



AC Schnitzer Clip-on bars BMW R nineT

2. Fitting... (continued)

Right side:

- From below, mark the desired position through the thread of the throttle twist grip, release stump from holder, remove throttle twist grip and drill **ONE (!)** 4 mm hole through the handlebar stump.
- Deburr drilled hole and countersink slightly.
- Push on throttle twist grip, fix stump in holder and secure throttle twist grip using the standard screw (M3.5 x 30 = 2Nm = as required). (Fig. 19)



- Position electrical unit and secure using the standard screw.
(M2.5 x 15 = 0.4Nm = as required!)
- Recreate plug connections. (Fig. 20)

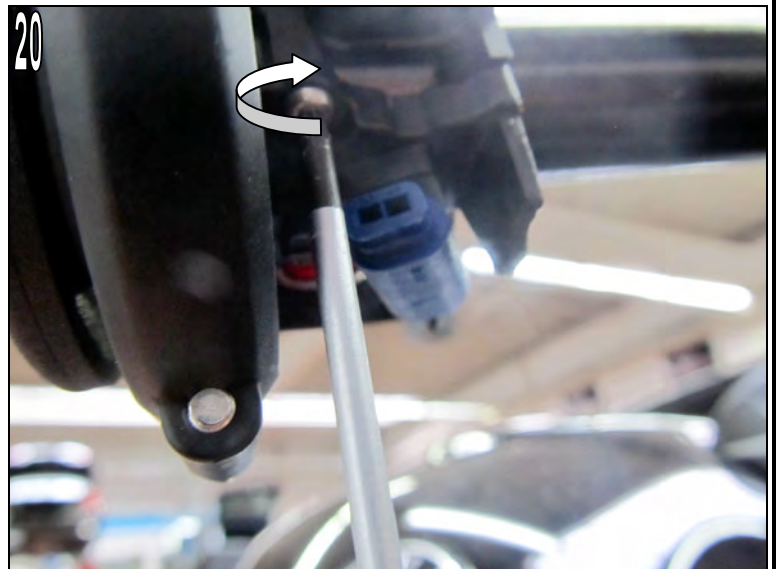

- Place lower cover on electrical unit, ensuring that the locking tabs are correctly positioned.
- Secure cover using standard fixing screw (M2.5 x 15 = 0.6Nm = as required). (Fig. 21).



Fitting Instructions

AC Schnitzer Clip-on bars BMW R nineT

2. Fitting... (cont'd.)

- Place handbrake fitting on handlebar stump, set in correct position and secure. (Fig. 22)



On the left:

- Mark the desired position through the fixing hole of the electrical unit, remove stump / electrical unit and drill **ONE (!)** 4mm hole through the stump.
- Deburr hole and countersink slightly.
- Fit electrical unit back on stump and mount on vehicle.

Secure electrical unit using standard screw (M3.5 x 30 = 1Nm = as required).

(Fig. 23)



- Place hand fitting on handlebar stump, position correctly and secure. (Fig. 24).

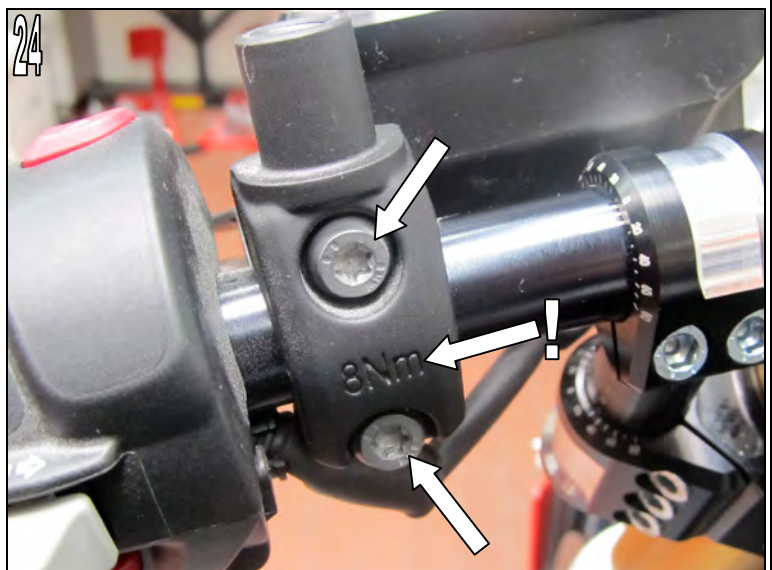

AC Schnitzer Clip-on bars BMW R nineT

2. Fitting... (cont'd)

On both sides:

- Refit rear view mirror to base holder.
- Where applicable, now fit the AC Schnitzer mirror extension BK 02.
- Position base part, stump holder and stump as required.
- Carefully turn the handlebars fully to the stops on both sides.
- Ensure adequate clearance of **all** components.
- Look out for cables and brake line! During the steering movement, do not crush / stretch any cables / brake line etc.
- Lay cables / brake line suitably and guide / secure with rubber straps (Fig. 25)



- Tighten all fixing bolts securely.
- Use correct tools at all times (socket head with guide pin)!
- See Fig. 26 for tightening torques and times!
- Remember to use thread lock!

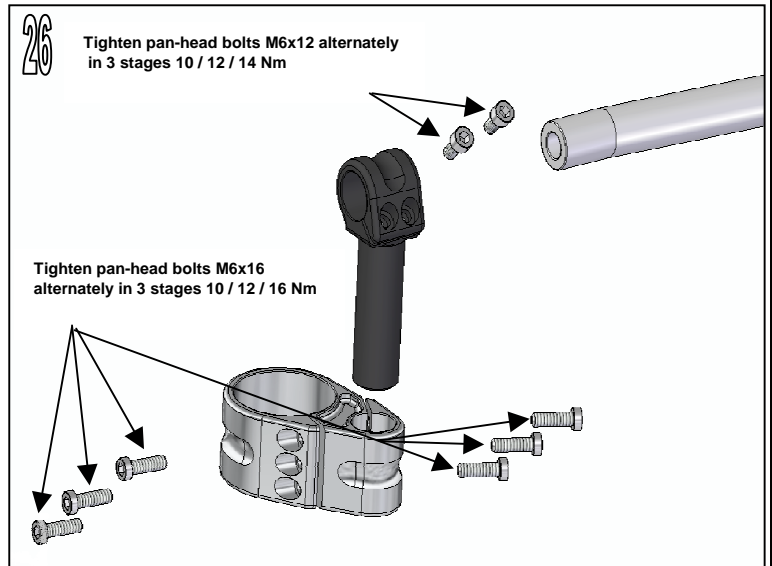

- Carry out a test ride.
- Then check all bolts for firm seat.
- Ensure proper function of all relevant components.
- Finally, press cover caps over socket-head screws.
- Inform rider of modified seating position / handling qualities!
- After fitting, the component must be demonstrated to an officially accredited inspector and a corresponding entry made in the vehicle documents. (Fig. 27).

